

9. APPLICATION DATA

(1) Installation of indoor unit

FOR MODEL SRR SERIES
R410A REFRIGERANT USED

RJJ012A002

- This installation manual illustrates the method of installing an indoor unit.
- For electrical wiring work, see instructions set out on the backside.
- For outdoor unit installation and refrigerant piping, refer to page25.

- A wired remote control unit is supplied separately as an optional part.
- While installing the unit, be sure to check the selection of installation place, power source specifications, usage limitation (piping length, height differences between indoor and outdoor units, power source voltage etc.) and installation spaces.

SAFETY PRECAUTIONS

- Before installation, read the "SAFETY PRECAUTIONS" carefully and strictly follow it during the installation work in order to protect yourself.
 - The precautionary items mentioned below are distinguished into two levels, **WARNING** and **CAUTION**.
 - **WARNING**: Wrong installation would cause serious consequences such as injuries or death.
 - **CAUTION**: Wrong installation might cause serious consequences depending on circumstances.
- Both mention the important items to protect your health and safety so strictly follow them by any means.
- Be sure to confirm no anomaly on the equipment by commissioning after completed installation and explain the operating methods as well as the maintenance methods of this equipment to the user according to the owner's manual.

- Keep the installation manual together with owner's manual at a place where any user can read at any time. Moreover if necessary, ask to hand them to a new user.
- Before starting the installation work, proper precautions (using suitable protective clothing, gloves etc.) should be taken by qualified installer.
- Pay attention not to fall down the tools, etc. when installing the unit at the high position.
- If unusual noise can be heard during operation, consult the dealer.
- The meanings of "Marks" used here are shown as follows:



Never do it under any circumstances.



Always do it according to the instruction.

WARNING

- **Installation must be carried out by the qualified installer.**
If you install the system by yourself, it may cause serious trouble such as water leaks, electric shocks, fire and personal injury, as a result of a system malfunction. Do not carry out the installation and maintenance work except the by qualified installer.
- **Install the system in full accordance with the installation manual.**
Incorrect installation may cause bursts, personal injury, water leaks, electric shocks and fire.
- **Be sure to use only for household and residence.**
If this appliance is installed in inferior environment such as machine shop and etc., it can cause malfunction.
- **Use the original accessories and the specified components for installation.**
If parts other than those prescribed by us are used, it may cause water leaks, electric shocks, fire and personal injury.
- **Install the unit in a location with good support.**
Unsuitable installation locations can cause the unit to fall resulting in material damage and personal injury.
- **Ventilate the working area well in the event of refrigerant leakage during installation.**
If the refrigerant comes into contact with naked flames, poisonous gas is produced.
- **When installing in small rooms, take prevention measures not to exceed the density limit of refrigerant in the event of leakage, referred by the formula (accordance with ISO5149).**
If the density of refrigerant exceeds the limit, consult the dealer and install the ventilation system, otherwise lack of oxygen can occur, which can cause serious accident.
- **After completing installation, check that no refrigerant leaks from the system.**
If refrigerant leaks into the room and comes into contact with an oven or other hot surface, poisonous gas is produced.
- **Use the prescribed pipes, flare nuts and tools for R410A.**
Using existing parts (for R22 or R407C) can cause the unit failure and serious accidents due to burst of the refrigerant circuit.
- **Do not put the drainage pipe directly into drainage channels where poisonous gases such as sulphide gas can occur.**
Poisonous gases will flow into the room through drainage pipe and seriously affect the user's health and safety. This can also cause the corrosion of the indoor unit and a resultant unit failure or refrigerant leak.
- **Ensure that no air enters in the refrigerant circuit when the unit is installed and removed.**
If air enters in the refrigerant circuit, the pressure in the refrigerant circuit becomes too high, which can cause burst and personal injury.
- **Do not process or splice the power cord, or share the socket with other power plugs.**
This may cause fire or electric shock due to defecting contact, defecting insulation and over-current etc.
- **Tighten the flare nut by torque wrench with specified method.**
If the flare nuts were tightened with excess torque, this may cause burst and refrigerant leakage after a long period.
- **The electrical installation must be carried out by the qualified electrician in accordance with "the norm for electrical work" and "national wiring regulation", and the system must be connected to the dedicated circuit.**
Power source with insufficient capacity and incorrect function done by improper work can cause electric shocks and fire.
- **Be sure to shut off the power before starting electrical work.**
Failure to shut off the power can cause electric shocks, unit failure or incorrect function of equipment.
- **Be sure to use the cables conformed to safety standard and cable ampacity for power distribution work.**
Unconformable cables can cause electric leak, anomalous heat production or fire.
- **This appliance must be connected to main power source by means of a circuit breaker or switch (fuse:16A) with a contact separation of at least 3mm.**
- **When plugging this appliance, a plug conforming to the norm IEC60884-1 must be used.**
- **Use the prescribed cables for electrical connection, tighten the cables securely in terminal block and relieve the cables correctly to prevent overloading the terminal blocks.**
Loose connections or cable mountings can cause anomalous heat production or fire.
- **Arrange the wiring in the control box so that it cannot be pushed up further into the box. Install the service panel correctly.**
Incorrect installation may result in overheating and fire.
- **Be sure to switch off the power source in the event of installation, inspection or servicing.**
If the power source is not shut off, there is a risk of electric shocks, unit failure or personal injury due to the unexpected start of fan.
- **Be sure to wear protective goggles and gloves while at work.**
- **Earth leakage breaker must be installed.**
If the earth leakage breaker is not installed, it can cause electric shocks.
- **Do not bundle or wind or process the power cord. Do not deform the power cord by treading it.**
This may cause fire or heating.
- **Do not vent R410A into the atmosphere: R410A is a fluorinated greenhouse gas, covered by the Kyoto Protocol with Global Warming Potential (GWP)=1975.**
- **Do not run the unit with removed panels or protections.**
Touching rotating equipments, hot surfaces or high voltage parts can cause personal injury due to entrapment, burn or electric shocks.
- **Do not perform any change of protective device itself or its setup condition.**
The forced operation by short-circuiting protective device of pressure switch and temperature controller or the use of non specified component can cause fire or burst.

CAUTION

- **Carry out the electrical work for ground lead with care.**
Do not connect the ground lead to the gas line, water line, lightning conductor or telephone line's ground lead. Incorrect grounding can cause unit faults such as electric shocks due to short-circuiting.
- **Use the circuit breaker of correct capacity. Circuit breaker should be able to disconnect all poles under over current.**
Using the incorrect one could cause the system failure and fire.
- **Install isolator or disconnect switch on the power source wiring in accordance with the local codes and regulations.**
The isolator should be locked in OFF state in accordance with EN60204-1.
- **Be sure to install indoor unit properly according to instruction manual so that drainage can run off smoothly.**
Improper installation of indoor unit can cause dropping water into the room and damaging personal property.
- **Install the drainage pipe to run off drainage securely according to the installation manual.**
Incorrect installation of the drainage pipe can cause dropping water into the room and damaging personal property.
- **Be sure to install the drainage pipe with descending slope of 1/100 or more, and not to make traps and air-bleedings.**
Check, if the drainage runs off securely during commissioning and ensure the space for inspection and maintenance.
- **After maintenance, all wiring, wiring ties and the like, should be returned to their original state and wiring route, and the necessary clearance from all metal parts should be secured.**
- **Secure a space for installation, inspection and maintenance specified in the manual.**
Insufficient space can result in accident such as personal injury due to falling from the installation place.
- **Take care when carrying the unit by hand.**
If the unit weights more than 20kg, it must be carried by two or more persons. Do not carry by the plastic straps, always use the carry handle
- **Do not install the unit in the locations listed below.**
 - Locations where carbon fiber, metal powder or any powder is floating.
 - Locations where any substances that can affect the unit such as sulphide gas, chloride gas, acid and alkaline can occur.
 - Vehicles and ships.
 - Locations where cosmetic or special sprays are often used.
 - Locations with direct exposure of oil mist and steam such as kitchen and machine plant.
 - Locations where any machines which generate high frequency harmonics are used.
 - Locations with salty atmospheres such as coastlines.
 - Locations with heavy snow (If installed, be sure to provide base flame and snow hood mentioned in the manual).
 - Locations where the unit is exposed to chimney smoke.
 - Locations at high altitude (more than 1000m high).
 - Locations with ammoniac atmospheres (e.g. organic fertilizer).
 - Locations with calcium chloride (e.g. snow melting agent).
 - Locations where heat radiation from other heat source can affect the unit.
 - Locations without good air circulation.
 - Locations with any obstacles which can prevent inlet and outlet air of the unit.
 - Locations where short circuit of air can occur (in case of multiple units installation).
 - Locations where strong air blows against the air outlet of outdoor unit.
 - Locations where something located above the unit could fall.
It can cause remarkable decrease in performance, corrosion and damage of components, malfunction and fire.
- **Do not install the indoor unit in the locations listed below (Be sure to install the indoor unit according to the installation manual for each model because each indoor unit has each limitation).**
 - Locations with any obstacles which can prevent inlet and outlet air of the unit.
 - Locations where vibration can be amplified due to insufficient strength of structure.
 - Locations where the infrared receiver is exposed to the direct sunlight or the strong light beam (in case of the infrared specification unit).
 - Locations where an equipment affected by high harmonics is placed (TV set or radio receiver is placed within 1m).
 - Locations where drainage cannot run off safely.
It can affect performance or function and etc.
- **Do not install the unit near the location where leakage of combustible gases can occur.**
If leaked gases accumulate around the unit, it can cause fire.
- **Do not install the unit where corrosive gas (such as sulfuric acid gas etc.) or combustible gas (such as thinner and petroleum gases) can accumulate or collect, or where volatile combustible substances are handled.**
Corrosive gas can cause corrosion of heat exchanger, breakage of plastic parts and etc. And combustible gas can cause fire.
- **Do not use the indoor unit at the place where water splashes may occur such as in laundries.**
Since the indoor unit is not waterproof, it can cause electric shocks and fire.
- **Do not install nor use the system close to the equipment that generates electromagnetic fields or high frequency harmonics.**
Equipment such as inverters, standby generators, medical high frequency equipments and telecommunication equipments can affect the system, and cause malfunctions and breakdowns. The system can also affect medical equipment and telecommunication equipment, and obstruct its function or cause jamming.
- **Do not place any variables which will be damaged by getting wet under the indoor unit.**
When the relative humidity is higher than 80% or drainage pipe is clogged, condensation or drainage water can drop and it can cause the damage of valuables.
- **Do not install the remote control at the direct sunlight.**
It can cause malfunction or deformation of the remote control.
- **Do not use the unit for special purposes such as storing foods, cooling precision instruments and preservation of animals, plants or art.**
It can cause the damage of the items.
- **Do not use any materials other than a fuse with the correct rating in the location where fuses are to be used.**
Connecting the circuit with copper wire or other metal thread can cause unit failure and fire.
- **Do not touch any buttons with wet hands.**
It can cause electric shocks.
- **Do not touch any refrigerant pipes with your hands when the system is in operation.**
During operation the refrigerant pipes become extremely hot or extremely cold depending the operating condition, and it can cause burn injury or frost injury.
- **Do not wash the inside of the air-conditioner.**
Water leakage and permanent damage may result.
Electrical hazard exists.

Check before installation work

- Model name and power source
- Refrigerant piping length
- Piping, wiring and miscellaneous small parts

Standard accessories (installation kit) Accessories for indoor unit	Q'ty
① Wireless remote control	1
② Remote control holder	1
③ Remote control signal receiver	1
④ Installation frame (for remote control signal receiver)	1
⑤ Wood screws (for remote control holder ø3.5 X 16mm)	2
⑥ Battery [R03 (AAA, Micro) 1.5V]	2
⑦ Joint (for drain hose)	1
⑧ Clamp (for drain hose) (big:1, small:1)	2
⑨ Washer (for suspension bolt M10)	8
⑩ Flat head machine screw (for remote control signal receiver M3.5x10)	2
⑪ Plate (display)	1
⑫ Pipe cover (big:1, small:1)	2
⑬ Band	4

Locally procured parts	Q'ty
A Sealing plate	1
B Sleeve	1
C Inclination plate	1
D Putty	1
E Drain hose (VP25)	1
F Suspension bolts (M10)	4
G Nuts (M10)	8
H Spring lock washers (M10)	4

Option parts (Separately sold parts)	Q'ty
Bottom air inlet kit (25, 35 models : UT-BAT1EF) (50, 60 models : UT-BAT2EF)	1

Necessary tools for the installation work
1 Plus headed driver
2 Knife
3 Saw
4 Tape measure
5 Hammer
6 Spanner wrench
7 Torque wrench [14.0-62.0N·m (1.4-6.2kgf·m)]
8 Hole core drill (65mm in diameter)
9 Wrench key (Hexagon) [4m/m]
10 Flaring tool set (Designed specifically for R410A)
11 Gas leak detector (Designed specifically for R410A)
12 Gauge for projection adjustment (Used when flare is made by using conventional flare tool)
13 Pipe bender

SELECTION OF INSTALLATION LOCATION

(Install at location that meets the following conditions, after getting approval from the customer)

Indoor unit

- Where there is no obstructions to the air flow and where the cooled and heated air can be evenly distributed.
 - A firm location that may sustain the weight of the unit, and do not cause the unit or the ceiling to vibrate.
 - A place where there will be enough space for servicing. (Where space mentioned below can be secured)
 - Where wiring and the piping work will be easy to conduct.
 - The place where receiving part is not exposed to the direct rays of the sun or the strong rays of the street lighting.
 - A place where it can be easily drained.
 - A place separated at least 1m away from the television or the radio. (To prevent interference to images and sounds.)
 - Places where this unit is not affected by the high frequency equipment or electric equipment.
 - Avoid installing this unit in place where there is much oil mist.
 - Places where there is no electric equipment or household under the installing unit.
 - Where the suction inlet of the unit is located far from the air inlet on the ceiling, the entire inside of ceiling acts as an air suction duct so that the capacity is reduced at the startup.
 - Areas where dew point is lower than around 28°C and relative humidity is lower than 80%.
- This indoor unit is tested under the condition of JIS (Japan Industrial Standard) high humidity condition and confirmed there is no problem. However, there is some risk of condensation drop if the air-conditioner is operated under the severer condition than mentioned above.
- If there is a possibility to use it under such a condition, attach additional insulation of 10 to 20mm thick for entire surface of indoor unit, refrigerant pipe and drain pipe.

Wireless remote control

- A place where the air-conditioner can be received the signal surely during operating the wireless remote control.
- Places where there is no affected by the TV and radio etc.
- Do not place where exposed to direct sunlight or near heat devices such as a stove.

Space for installation and service

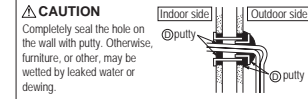
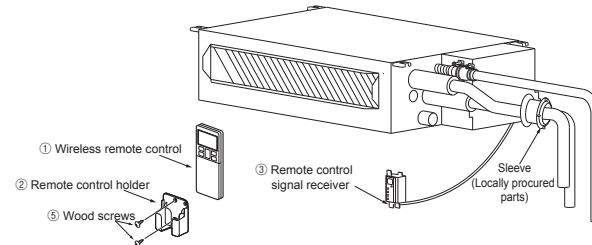
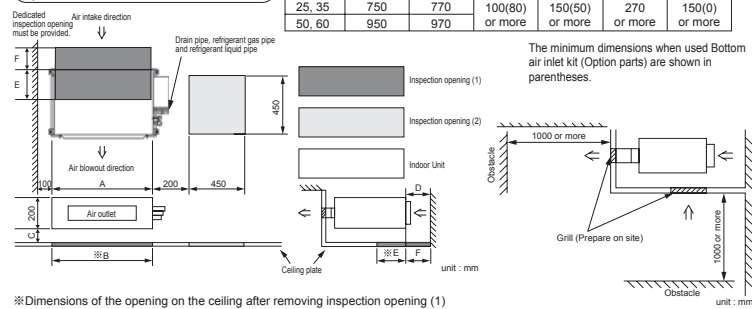

Inspection opening for services

Service	Inspection opening (1)	Inspection opening (2)
Clamping of the flare of required and gas refrigerant pipe	Not Use	Use
Drain pipe connection	Not Use	Use
Installation and removal of blower	Use	Not Use
Control box		
Connecting wire (between indoor and outdoor)	Not Use	Use
Unit display section (Remote control signal receiver)	Not Use	Use
Replace drain pump	Not Use	Use
Replace heat exch sensor	Not Use	Use
Replace air filter	Use	Not Use

INSTALLATION OF INDOOR UNIT

- Remove bracket from the unit after unpacking according to process as shown below.

- (1) Loosen 2 screws.
- (2) Remove bracket.
- (3) Tighten the screws.

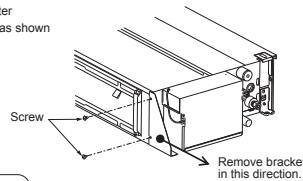

Suspension Bolt Location

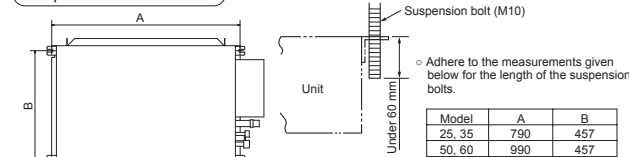

Drilling of hole and fixture of sleeve (Locally procured parts)

When drilling the wall that contains a metal lath, wire lath or metal plate, be sure to use pipe hole sleeve sold separately.

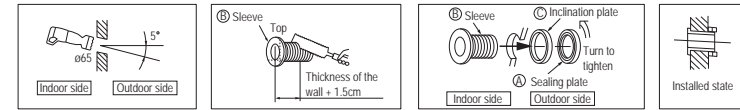

- Drill a hole with whole core drill.
- In case of rear piping draw out, cut off the lower and the right side portions of the sleeve collar.
- * Sleeve is for use in refrigerant piping work. Please install another pipe separately for drain piping work.

Pipe locations

All models

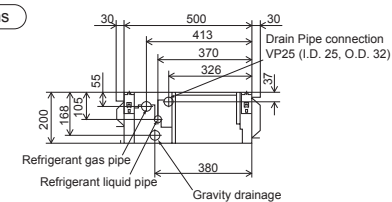

INSTALLATION OF INDOOR UNIT

Installing the main unit

- Attach the washers and nuts to the suspension bolts.
- Attach the hanging tool to the above nuts, and tighten the nuts.

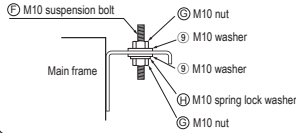

Securing the suspension bolts

If steel embedded ceiling

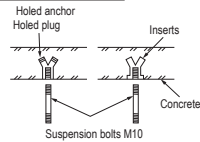

If wooden ceiling

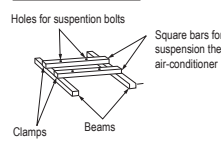

- Secure the suspension bolts firmly following the illustrations and other instructions.

Adjustment for horizontality

- Either use a level vial, or adjust the level according to the method below.

- Adjust so the bottom side of the unit will be leveled with the water surface as illustrated below.

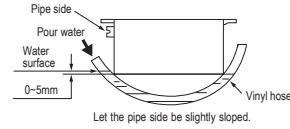

- If the unit is not leveled, it may cause malfunctions or inoperation of the float switch.

Air inlet and outlet size

- Size of air inlet and outlet of the plate.

Model	A		B
	Inlet	Outlet	
25, 35	160	99	660
50, 60			860

unit : mm

CONNECTION OF REFRIGERANT PIPINGS

Preparation

Keep the openings of the pipes covered with tapes etc. to prevent dust, sand, etc. from entering them.

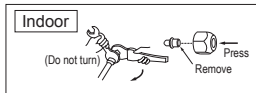

- Remove the flared nuts. (on both liquid and gas sides)

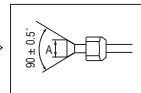

- Install the removed flared nuts to the pipes to be connected, then flared the pipes.

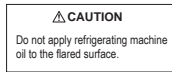

Flaring work

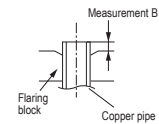

Copper pipe diameter	Measurement B (mm)		
	Clutch type flare tool for R410A	Conventional (R22) flare tool	
		Clutch type	Wing nut type
φ6.35	0.0 - 0.5	1.0 - 1.5	1.5 - 2.0
φ9.52	0.0 - 0.5	1.0 - 1.5	1.5 - 2.0
φ12.7	0.0 - 0.5	1.0 - 1.5	2.0 - 2.5

Use a flare tool designed for R410A or a conventional flare tool.
Note that measurement B (protrusion from the flaring block) will vary depending on the type of a flare tool in use.
If a conventional flare tool is used, use a copper pipe gauge or a similar instrument to check protrusion so that you can keep measurement B to a correct value.

Connection

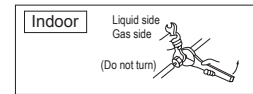

- Connect the pipes on both liquid and gas sides.
- Tighten the nuts to the following torque.
Liquid side (φ6.35) : 14.0 - 18.0 N·m (1.4 - 1.8 kgf·m)
Gas side (φ9.52) : 34.0 - 42.0 N·m (3.4 - 4.2 kgf·m)
(φ12.7) : 49.0 - 61.0 N·m (4.9 - 6.1 kgf·m)

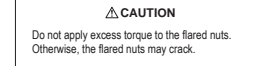

- Cover the flare connection part of the indoor unit with attached insulation material after a gas leakage inspection, and tighten both ends with attached bands.
- Make sure to insulate both gas pipes and liquid pipes completely.
※Incomplete insulation may cause dew condensation or water dripping.
- Use heat-resistant (120 °C or more) insulations on the gas side pipes.
- In case of using at high humidity condition, reinforce insulation of refrigerant pipes.
Surface of insulation may cause dew condition or water dripping, if insulations are not reinforced.

<The case of using thickness of insulation is 10mm>

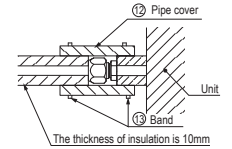

<The case of using reinforced insulation>

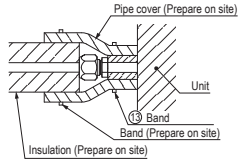

DRAIN PIPE

- Install the drain pipe according to the installation manual in order to drain properly.
Imperfection in draining may cause flood indoors and wetting the household goods, etc.
- Do not put the drain pipe directly into the ditch where toxic gas such as sulfur, the other harmful and inflammable gas is generated. Toxic gas would flow into the room and it would cause serious damage to user's health and safety (some poisoning or deficiency of oxygen). In addition, it may cause corrosion of heat exchanger and bad smell.
- Connect the pipe securely to avoid water leakage from the joint.
- Insulate the pipe properly to avoid condensation drop.
- Check if the water can flow out properly from both the drain outlet on the indoor unit and the end of the drain pipe after installation.

Work procedure

- Insert the joint to the drain hose on the indoor unit and fix it securely with the clamp (small).
Do not apply adhesives on this end.
- Connect the drain pipe (VP25) to the joint and fix it securely with the clamp (big).
- Make sure to make descending slope of greater than 1/100 and do not make up-down bend and/or trap in the midway.
Pay attention not to give stress on the pipe on the indoor unit side, and support and fix the pipe as close place to the unit as possible when connecting the drain pipe.
Do not set up air vent.

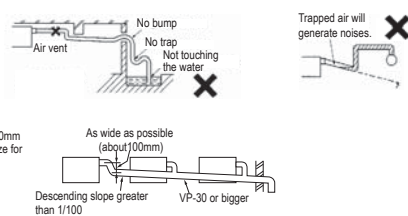
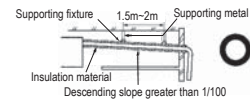
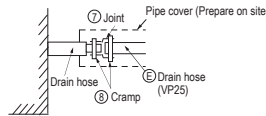

- When sharing a drain pipe for more than one unit, lay the main pipe 100mm below the drain outlet of the unit. In addition, select VP-30 or bigger size for main drain pipe.

- Insulate the drain pipe.

- Be sure to insulate the joint and the drain pipe installed indoor otherwise it may cause dew condensation and water leakage.

Drain up

- The position for drain pipe outlet can be raised up to 600mm above the ceiling. Use elbows for installation to avoid obstacles inside ceiling. If the horizontal drain pipe is too long before vertical pipe, the backflow of water will increase when the unit is stopped, and it may cause overflow of water from the drain pan on the indoor unit. In order to avoid overflow, keep the horizontal pipe length and offset of the pipe within the limit shown in the figure below.

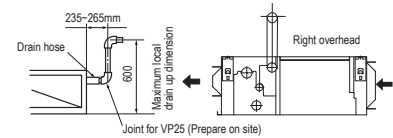

Drain test

- Conduct a drainage test after completion of the electrical work and piping work.
- During the trial, make sure that drain flows properly through the piping and that no water leaks from connections.
- In case of a new building, conduct the test before it is furnished with the ceiling.
- Be sure to conduct this test even when the unit is installed in the heating season.

Procedures of drain test

- Supply about 1000 cc of water to the unit through the air outlet by using a feed water pump.
- Check the drain while cooling operation.

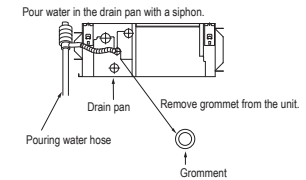

Outline of bottom drain piping work

- If the bottom drain piping can be done with a descending gradient (1/50-1/100), it is possible to connect the pipes as shown in the drawing below.

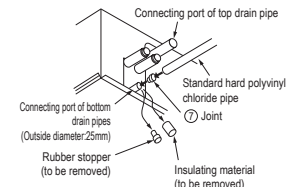

ELECTRICAL WIRING WORK

Preparation of indoor unit ○ In case of faulty wiring connection, indoor unit does not operate. Then, run lamp turns on and timer lamp blinks.

Mounting of connecting wires

- Remove the control lid.
- Remove the wiring clamp.
- Connect the connecting wire to the terminal block.
 - Connect the connection wire securely. If the wire is not affixed completely, contact will be poor, and it is dangerous as the terminal block may heat up and catch fire.
 - Take care not to confuse the terminal numbers for indoor and outdoor connections.
 - Fix the connecting wire by wiring clamp.
 - Connect the connector of the remote control signal receiver to the relay wiring.
 - Attach the control lid.

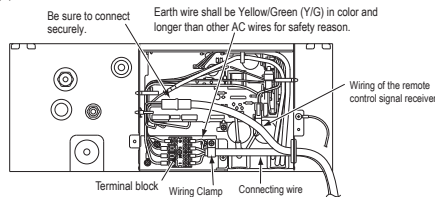

Use cables for interconnection wiring to avoid loosening of the wires. CENELEC code for cables Required field cables.

H05RN4G1.5 (example) or 245IEC57
 H Harmonized cable type
 05 300/500 volts
 R Natural-and/or synth. rubber wire insulation
 N Polychloroprene rubber conductors insulation
 R Stranded core
 4or5 Number of conductors
 G One conductor of the cable is the earth conductor (yellow/green)
 1.5 Section of copper wire (mm²)

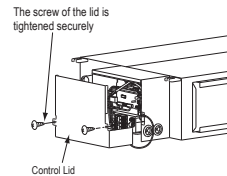

Securing the remote control signal receiver

Cut off this section if it interferes with the wall.

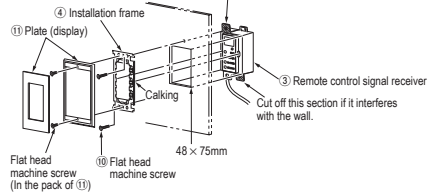

- Open a through-hole on the wall to install the reception face for the remote control signal receiver ③.
- Insert the remote control signal receiver ③ in the installation frame ④, and fix the calking section.
- Fix the installation frame ④ on the wall using the flat head machine screws ②.
- Fix the plate (display) ① on the installation frame ④ using the flat head machine screws packed together with the plate (display) ①.

INSTALLATION OF WIRELESS REMOTE CONTROL

Mounting method of battery

- Pull out the cover and mount the batteries [R03 (AAA, Micro), ×2 pieces] in the body regularly. (Fit the poles with the indication marks, ⊕ & ⊖ without fail)
- Do not use new and old batteries together.

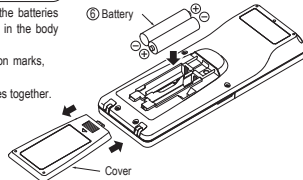

Fixing to pillar or wall

- Conventionally, operate the wireless remote control by holding in your hand.
- Avoid installing it on a clay wall etc.

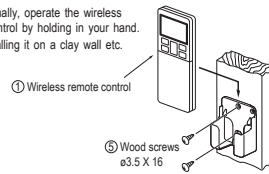

INSTALLING TWO AIR-CONDITIONERS IN THE SAME ROOM

When two air-conditioners are installed in the same room, use this setting when the two air-conditioners are not operated with one wireless remote control. Set the wireless remote control and indoor unit.

Setting the wireless remote control

- Pull out the cover and take out batteries.
- Disconnect the switching line next to the battery with wire cutters.

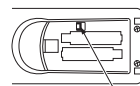

Disconnect

- Insert batteries. Close the cover.

Setting an indoor unit

- Turn off the power source, and turn it on after 1 minute.
- Point the wireless remote control that was set according to the procedure described on the left side at the unit display section and send a signal by pressing the ACL switch on the wireless remote control. Since the signal is sent in about 6 seconds after the ACL switch is pressed, point the wireless remote control at the unit display section for some time.
- Check that the reception buzzer sound "pip" is emitted from the indoor unit. At completion of the setting, the indoor unit emits a buzzer sound "pip". (If no reception tone is emitted, start the setting from the beginning again.)

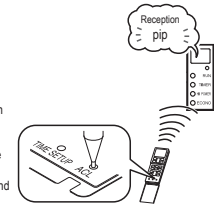

HOW TO RELOCATE OR DISPOSE OF THE UNIT

- In order to protect the environment, be sure to pump down (recovery of refrigerant).
- Pump down is the method of recovering refrigerant from the indoor unit to the outdoor unit when the pipes are removed from the unit.
- Forced cooling operation: Turn off power source. Turn on power source again after a while. Then, press the ON/OFF button continuously for at least 5 seconds. (The operation will start.)

<How to pump down>

- Connect charge hose to check joint of outdoor unit.
- Liquid side : Close the liquid valve with hexagon wrench key.
 Gas side : Fully open the gas valve.
 Carry out cooling operation. (If indoor temperature is low, operate forced cooling operation.)
- After low pressure gauge become 0.01MPa, stop cooling operation and close the gas valve.

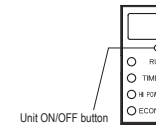

TERMINAL CONNECTION FOR AN INTERFACE

- Remove the control lid. (Remove the screw.)
- There is a terminal (respectively marked with CNS) for the indoor control board. In connecting an interface, connect to the respective terminal securely with the connection harness supplied with an optional "Interface connection kit SC-BIKN-E" and fasten the connection harness onto the indoor control box with the clamp supplied with the kit. For more details, please refer to the user's manual of your "Interface connection kit SC-BIKN-E".

INSTALLATION TEST CHECK POINTS

Check the following points again after completion of the installation, and before turning on the power. Conduct a test run again and ensure that the unit operates properly. Explain to the customer how to use the unit and how to take care of the unit following the installation manual.

After installation

- Power cables and connecting wires are securely fixed to the terminal block. (Both indoor and outdoor)
- The power source voltage is correct as the rating.
- The drain hose is fixed securely.
- Service valve is fully open.
- No gas leaks from the joints of the service valve.
- The pipe joints for indoor and outdoor pipes have been insulated.
- The screw of the control lid is tightened securely.

Test run

- Air-conditioning operation is normal.
- No abnormal noise.
- Water drains smoothly.
- Protective functions are not working.
- The remote control is normal.
- Operation of the unit has been explained to the customer. (Three-minutes restart preventive timer) When the air-conditioner is restarted or when changing the operation, the unit will not start operating for approximately 3 minutes. This is to protect the unit and it is not a malfunction.

(2) Installation of outdoor unit

RWC012A044A

**Model SRC20-25-35-50
DXC06-09-12-18
R410A REFRIGERANT USED**

- This installation manual deals with outdoor units and general installation specifications only. For indoor units, refer to page 21.
- When install the unit, be sure to check whether the selection of installation place, power source specifications, usage limitation (piping length, height differences between indoor and outdoor units, power source voltage and etc.) and installation spaces.

SAFETY PRECAUTIONS

- Read the "SAFETY PRECAUTIONS" carefully first of all and strictly follow it during the installation work in order to protect yourself.
- The precautionary items mentioned below are distinguished into two levels, **WARNING** and **CAUTION**.
 - WARNING** : Wrong installation would cause serious consequences such as injuries or death.
 - CAUTION** : Wrong installation might cause serious consequences depending on circumstances.
 Both mentions the important items to protect your health and safety so strictly follow them by any means.
- Be sure to confirm no anomaly on the equipment by commissioning after completed installation and explain the operating methods as well as the maintenance methods of this equipment to the user according to the owner's manual.
- Keep the installation manual together with owner's manual at a place where any user can read at any time. Moreover if necessary, ask to hand them to a new user.
- For installing qualified personnel, take precautions in respect to themselves by using suitable protective clothing, groves, etc., and then perform the installation works.
- Please pay attention not to fall down the tools, etc. when installing the unit at the high position.
- If unusual noise can be heard during operation, consult the dealer.
- The meanings of "Marks" used here are shown as follows:

	Never do it under any circumstances.			Always do it according to the instruction.
--	--------------------------------------	--	--	--

WARNING

	<ul style="list-style-type: none"> • Installation must be carried out by the qualified installer. If you install the system by yourself, it may cause serious trouble such as water leaks, electric shocks, fire and personal injury, as a result of a system malfunction. Do not carry out the installation and maintenance work except the by qualified installer. • Install the system in full accordance with the installation manual. Incorrect installation may cause bursts, personal injury, water leaks, electric shocks and fire. • Be sure to use only for household and residence. If this appliance is installed in inferior environment such as machine shop and etc., it can cause malfunction. • When installing in small rooms, take prevention measures not to exceed the density limit of refrigerant in the event of leakage, referred by the formula (accordance with ISO5149). If the density of refrigerant exceeds the limit, please consult the dealer and install the ventilation system, otherwise lack of oxygen can occur, which can cause serious accident. • Use the original accessories and the specified components for installation. If parts other than those prescribed by us are used, It may cause water leaks, electric shocks, fire and personal injury. • Install the unit in a location with good support. Unsuitable installation locations can cause the unit to fall and cause material damage and personal injury. • Ensure the unit is stable when installed, so that it can withstand earthquakes and strong winds. Unsuitable installation locations can cause the unit to fall and cause material damage and personal injury. 	<ul style="list-style-type: none"> • Ventilate the working area well in the event of refrigerant leakage during installation. If the refrigerant comes into contact with naked flames, poisonous gas is produced. • Use the prescribed pipes, flare nuts and tools for R410A. Using existing parts (for R22 or R407C) can cause the unit failure and serious accidents due to burst of the refrigerant circuit. • Tighten the flare nut by torque wrench with specified method. If the flare nut were tightened with excess torque, this may cause burst and refrigerant leakage after a long period. • Do not open the service valves for liquid line and gas line until completed refrigerant piping work, air tightness test and evacuation. If the compressor is operated in state of opening service valves before completed connection of refrigerant piping work, air can be sucked into refrigerant circuit, which can cause burst or personal injury due to anomalously high pressure in the refrigerant. • The electrical installation must be carried out by the qualified electrician in accordance with "the norm for electrical work" and "national wiring regulation", and the system must be connected to the dedicated circuit. Power source with insufficient capacity and incorrect function done by improper work can cause electric shocks and fire. • Be sure to shut off the power before starting electrical work. Failure to shut off the power can cause electric shocks, unit failure or incorrect function of equipment. • Be sure to use the cables conformed to safety standard and cable ampacity for power distribution work. Unconformable cables can cause electric leak, anomalous heat production or fire. • This appliance must be connected to main power source by means of a 	<ul style="list-style-type: none"> circuit breaker or switch (fuse:16A) with a contact separation of at least 3mm. • Arrange the wiring in the control box so that it cannot be pushed up further into the box. Install the service panel correctly. Incorrect installation may result in overheating and fire. • Use the prescribed cables for electrical connection, tighten the cables securely in terminal block and relieve the cables correctly to prevent overloading the terminal blocks. Loose connections or cable mountings can cause anomalous heat production or fire. • Be sure to fix up the service panels. Incorrect fixing can cause electric shocks or fire due to intrusion of dust or water. • Be sure to switch off the power source in the event of installation, inspection or servicing. If the power source is not shut off, there is a risk of electric shocks, unit failure or personal injury due to the unexpected start of fan. • Stop the compressor before removing the pipe after shutting the operation valve on pump down work. If the pipe is removed when the compressor is in operation with the service valve open, air would be mixed in the refrigeration circuit and it could cause explosion and injuries due to abnormal high pressure in the cooling cycle. • Only use prescribed option parts. The installation must be carried out by the qualified installer. If you install the system by yourself, it can cause serious trouble such as water leaks, electric shocks, fire. • Be sure to wear protective goggles and gloves while at work. • Earth leakage breaker must be installed. If the earth leakage breaker is not installed, it can cause electric shocks.
	<ul style="list-style-type: none"> • Ensure that no air enters in the refrigerant circuit when the unit is installed and removed. If air enters in the refrigerant circuit, the pressure in the refrigerant circuit becomes too high, which can cause burst and personal injury. • Do not processing, splice the power cord, or share a socket with other power plugs. This may cause fire or electric shock due to defecting contact, defecting insulation and over-current etc. 	<ul style="list-style-type: none"> • Do not bundling, winding or processing for the power cable. Or, do not deforming the power plug due to tread it. This may cause fire or heating. • Do not run the unit with removed panels or protections. Touching rotating equipments, hot surfaces or high voltage parts can cause personal injury due to entrapment, burn or electric shocks. 	<ul style="list-style-type: none"> • Do not perform any change of protective device itself or its setup condition. The forced operation by short-circuiting protective device of pressure switch and temperature controller or the use of non specified component can cause fire or burst.

⚠ CAUTION

	<ul style="list-style-type: none"> • Carry out the electrical work for ground lead with care. Do not connect the ground lead to the gas line, water line, lightning conductor or telephone line's ground lead. Incorrect grounding can cause unit faults such as electric shocks due to short-circuiting.
	<ul style="list-style-type: none"> • Use the circuit breaker for all pole correct capacity. Circuit breaker should be the one that disconnect all poles under over current. Using the incorrect circuit breaker, it can cause the unit malfunction and fire. • Install isolator or disconnect switch on the power source wiring in accordance with the local codes and regulations. The isolator should be locked in OFF state in accordance with EN60204-1. • After maintenance, all wiring, wiring ties and the like, should be returned to their original state and wiring route, and the necessary clearance from all metal parts should be secured. • Secure a space for installation, inspection and maintenance specified in the manual. Insufficient space can result in accident such as personal injury due to falling from the installation place. • Take care when carrying the unit by hand. If the unit weights more than 20kg, it must be carried by two or more persons. Do not carry by the plastic straps, always use the carry handle when carrying the unit by hand. Use gloves to minimize the risk of cuts by the aluminum fins. • Dispose of any packing materials correctly. Any remaining packing materials can cause personal injury as it contains nails and wood. And to avoid danger of suffocation, be sure to keep the plastic wrapper away from children and to dispose after tear it up. • Be sure to insulate the refrigerant pipes so as not to condense the ambient air moisture on them. Insufficient insulation can cause condensation, which can lead to moisture damage on the ceiling, floor, furniture and any other valuables. • When perform the air-conditioner operation (cooling or drying operation) in which ventilator is installed in the room. In this case, using the air-conditioner in parallel with the ventilator, there is the possibility that drain water may backflow in accordance with the room lapse into the negative pressure status. Therefore, set up the opening port such as incorporate the air into the room that may appropriate to ventilation (For example; Open the door a little). In addition, just as above, so set up the opening port if the room lapse into negative pressure status due to register of the wind for the high rise apartment etc.
	<ul style="list-style-type: none"> • Do not install the unit in the locations listed below. <ul style="list-style-type: none"> • Locations where carbon fiber, metal powder or any powder is floating. • Locations where any substances that can affect the unit such as sulphide gas, chloride gas, acid and alkaline can occur. • Vehicles and ships. • Locations where cosmetic or special sprays are often used. • Locations with direct exposure of oil mist and steam such as kitchen and machine plant. • Locations where any machines which generate high frequency harmonics are used. • Locations with salty atmospheres such as coastlines. • Locations with heavy snow (If installed, be sure to provide base flame and snow hood mentioned in the manual). • Locations where the unit is exposed to chimney smoke. • Locations at high altitude (more than 1000m high). • Locations with ammoniac atmospheres (e.g. organic fertilizer). • Locations with calcium chloride (e.g. snow melting agent). • Locations where heat radiation from other heat source can affect the unit. • Locations without good air circulation. • Locations with any obstacles which can prevent inlet and outlet air of the unit. • Locations where short circuit of air can occur (in case of multiple units installation). • Locations where strong air blows against the air outlet of outdoor unit. • Locations where something located above the unit could fall. It can cause remarkable decrease in performance, corrosion and damage of components, malfunction and fire. • Do not install the outdoor unit in the locations listed below. <ul style="list-style-type: none"> • Locations where discharged hot air or operating sound of the outdoor unit can bother neighborhood. • Locations where outlet air of the outdoor unit blows directly to an animal or plants. The outlet air can affect adversely to the plant etc. • Locations where vibration can be amplified and transmitted due to insufficient strength of structure. • Locations where vibration and operation sound generated by the outdoor unit can affect seriously (on the wall or at the place near bed room). • Locations where an equipment affected by high harmonics is placed (TV set or radio receiver is placed within 1m). • Locations where drainage cannot run off safely. It can affect surrounding environment and cause a claim. • Do not install the unit near the location where leakage of combustible gases can occur. If leaked gases accumulate around the unit, it can cause fire. • Do not install the unit where corrosive gas (such as sulfurous acid gas etc.) or combustible gas (such as thinner and petroleum gases) can accumulate or collect, or where volatile combustible substances are handled. Corrosive gas can cause corrosion of heat exchanger, breakage of plastic parts and etc. And combustible gas can cause fire. • Do not install nor use the system close to the equipment that generates electromagnetic fields or high frequency harmonics. Equipment such as inverters, standby generators, medical high frequency equipments and telecommunication equipments can affect the system, and cause malfunctions and breakdowns. The system can also affect medical equipment and telecommunication equipment, and obstruct its function or cause jamming. • Do not install the outdoor unit in a location where insects and small animals can inhabit. Insects and small animals can enter the electric parts and cause damage or fire. Instruct the user to keep the surroundings clean. • Do not use the base flame for outdoor unit which is corroded or damaged due to long periods of operation. Using an old and damage base flame can cause the unit falling down and cause personal injury. • Do not use any materials other than a fuse with the correct rating in the location where fuses are to be used. Connecting the circuit with copper wire or other metal thread can cause unit failure and fire. • Do not touch any buttons with wet hands. It can cause electric shocks. • Do not touch any refrigerant pipes with your hands when the system is in operation. During operation the refrigerant pipes become extremely hot or extremely cold depending the operating condition, and it can cause burn injury or frost injury. • Do not touch the suction or aluminum fin on the outdoor unit. This may cause injury. • Do not put anything on the outdoor unit and operating unit. This may cause damage the objects or injury due to falling to the object. • Do not use the unit for special purposes such as storing foods, cooling precision instruments and preservation of animals, plants or art. • Do not clean up the unit with water.

Check before installation work

- Model name and power source
- Refrigerant piping length
- Piping, wiring and miscellaneous small parts
- Indoor unit installation manual

Accessories for outdoor unit		Q'ty
①	Grommet (Heat pump type only)	1
	Model SRC20~35 DXC06~12 Model SRC50/DXC18	4

②	Drain elbow (Heat pump type only)	1
Option parts		Q'ty
③	Sealing plate	1
④	Sleeve	1
⑤	Inclination plate	1
⑥	Putty	1
⑦	Drain hose (extension hose)	1
⑧	Piping cover (for insulation of connection piping)	1

Necessary tools for the installation work		
9	Wrench key (Hexagon) [4m/m]	
10	Vacuum pump	
11	Vacuum pump adapter (Anti-reverse flow type) (Designed specifically for R410A)	
12	Gauge manifold (Designed specifically for R410A)	
13	Charge hose (Designed specifically for R410A)	
14	Flaring tool set (Designed specifically for R410A)	
15	Gas leak detector (Designed specifically for R410A)	
16	Gauge for projection adjustment (Used when flare is made by using conventional flare tool)	
1	Plus headed driver	
2	Knife	
3	Saw	
4	Tape measure	
5	Hammer	
6	Spanner wrench	
7	Torque wrench [14.0~62.0N·m (1.4~6.2kgf·m)]	
8	Hole core drill (65mm in diameter)	

Notabilia as a unit designed for R410A

- Do not use any refrigerant other than R410A. R410A will rise to pressure about 1.6 times higher than that of a conventional refrigerant.
A cylinder containing R410A has a pink indication mark on the top.
- A unit designed for R410A has adopted a different size indoor unit serviv valve charge port and a different size check joint provided in the unit to prevent the charging of a wrong refrigerant by mistake.
The processed dimension of the flared part of a refrigerant pipe and a flare nut's parallel side measurement have also been altered to raise strength against pressure.
Accordingly, you are required to arrange dedicated R410A tools listed in the table on the left before installing or servicing this unit.
- Do not use a charge cylinder. The use of a charge cylinder will cause the refrigerant composition to change, which results in performance degradatoin.
- In charging refrigerant, always take it out from a cylinder in the liquid phase.
- All indoor units must be models designed exclusively for R410A. Check connectable indoor unit models in a catalog, etc. (A wrong indoor unit, if connected into the system, will impair proper system operation)

1. HAULAGE AND INSTALLATION (Take particular care in carrying in or moving the unit, and always perform such an operation with two or more persons.)

CAUTION When a unit is hoisted with slings for haulage, take into consideration the offset of its gravity center position. If not properly balanced, the unit can be thrown off-balance and fall.

1) Delivery

- Deliver the unit as close as possible to the installation site before removing it from the packaging.
- When you have to unpack the unit for a compelling reason before you haul it to the installation point, hoist the unit with nylon slings or ropes and protection pads so that you may not damage the unit.

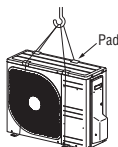

2) Portage

- The right hand side of the unit as viewed from the front (diffuser side) is heavier. A person carrying the right hand side must take heed of this fact. A person carrying the left hand side must hold with his right hand the handle provided on the front panel of the unit and with his left hand the corner column section.

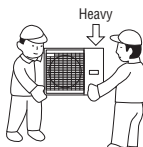

3) Selecting the installation location

Be careful of the following conditions and choose an installation place.

- Where air is not trapped.
- Where the installation fittings can be firmly installed.
- Where wind does not hinder the intake and outlet pipes.
- Out of the heat range of other heat sources.
- A place where stringent regulation of electric noises is not applicable.
- Where it is safe for the drain water to be discharged.
- Where noise and hot air will not bother neighboring residents.
- Where snow will not accumulate.
- Where strong winds will not blow against the outlet pipe.
- A place where no TV set or radio receiver is placed within 1m. (If electrical interference is caused, seek a place less likely to cause the problem)
- If a operation is conducted when the outdoor air temperature is -5°C lower, the outdoor unit should be installed at a place where it is not influenced by natural wind.
- Where it is likely that the unit is subjected to strong winds, provide wind guards according to the following guidelines. Strong winds can cause performance degradation, an accidental stop due to a rise of high pressure and a broken fan.

Do not install the unit in places which exposed to sea breeze (e.g. coastal area) or calcium chloride (e.g. snow melting agent), exposed to ammonia substance (e.g. organic fertilizer).

4) Caution about selection of installation location

- (1) If the unit is installed in the area where the snow will accumulate, following measures are required. The bottom plate of unit and intake, outlet may be blocked by snow.

- 1 Install the unit on the base so that the bottom is higher than snow cover surface.
- 2 Install the unit under or provide the roof on site.

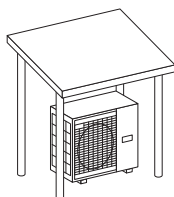
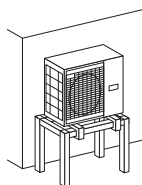

- Since drain water generated by defrost control may freeze, following measures are required.
- Do not execute drain piping work by using a drain elbow and drain grommets (accessories). [Refer to Drain piping work.]

- (2) If the unit can be affected by strong wind, following measures are required. Strong wind can cause damage of fan (fan motor), or can cause performance degradation, or can trigger anomalous stop of the unit due to rising of high pressure.

- 1 Place the unit outlet side is turned to the wall.
- 2 Install so the direction of the air from the blowing outlet will be perpendicular to the direction of the wind.

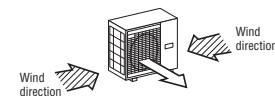
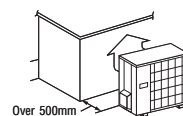

5) Installation space

- Walls surrounding the unit in the four sides are not acceptable.
- There must be a 1-meter or larger space in the above.
- When more than one unit are installed side by side, provide a 250mm or wider interval between them as a service space. In order to facilitate servicing of controllers, please provide a sufficient space between units so that their top plates can be removed easily.
- Where a danger of short-circuiting exists, install guide louvers.
- When more than one unit are installed, provide sufficient intake space consciously so that short-circuiting may not occur.
- Where piling snow can bury the outdoor unit, provide proper snow guards.

Example installation Size	Model SRC20~50/DXC06~18 (mm)			
	I	II	III	IV
L1	Open	280	280	180
L2	100	75	Open	Open
L3	100	80	80	80
L4	250	Open	250	Open

The height of a wall is 1200mm or less.

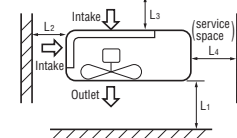

6) Installation

- ① Anchor bolt fixed position

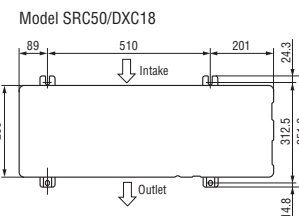
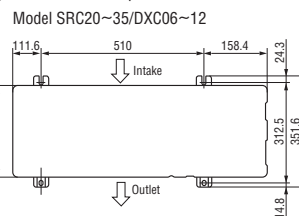

- ② Notabilia for installation

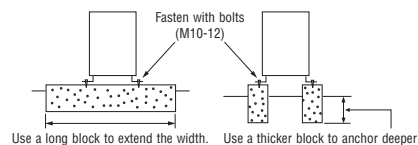

- In installing the unit, fix the unit's legs with bolts specified on the above.
- The protrusion of an anchor bolt on the front side must be kept within 15mm.
- Securely install the unit so that it does not fall over during earthquakes or strong winds, etc.
- Refer to the above illustrations for information regarding concrete foundations.
- Install the unit in a level area. (With a gradient of 5mm or less.) Improper installation can result in a compressor failure, broken piping within the unit and abnormal noise generation.

2. REFRIGERANT PIPING WORK

1) Restrictions on unit installation and use

- Check the following points in light of the indoor unit specifications and the installation site.
- Observe the following restrictions on unit installation and use. Improper installation can result in a compressor failure or performance degradation.
- Additional refrigerant charge is not required at all (Model SRC20~35/DXC06~12).

Restrictions		Dimensional restrictions		Marks appearing in the drawing on the right
		Model SRC20~35/DXC06~12	Model SRC50/DXC18	
Main pipe length		15m or less	25m or less	L
Elevation difference between indoor and outdoor units	When the outdoor unit is positioned higher,	10m or less	15m or less	H
	When the outdoor unit is positioned lower,	10m or less	15m or less	H

CAUTION The use restrictions appearing in the table above are applicable to the standard pipe size combinations shown in the table below.

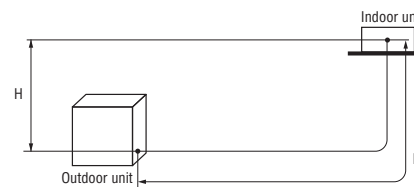

2) Determination of pipe size

Determine refrigerant pipe size pursuant to the following guidelines based on the indoor unit specifications.

	Model SRC20~35/DXC06~12		Model SRC50/DXC18	
	Gas pipe	Liquid pipe	Gas pipe	Liquid pipe
Outdoor unit connected	ø9.52 Flare	ø6.35 Flare	ø12.7 Flare	ø6.35 Flare
Refrigerant piping (branch pipe L)	ø9.52	ø6.35	ø12.7	ø6.35
Indoor unit connected	ø9.52	ø6.35	ø12.7	ø6.35

When pipe is brazing.

About brazing

Brazing must be performed under a nitrogen gas flow.

Without nitrogen gas, a large quantity of foreign matters (oxidized film) are created, causing a critical failure from capillary tube or expansion valve clogging.

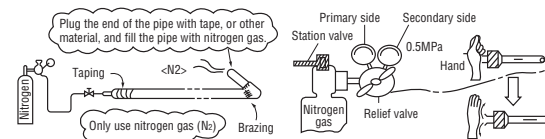

3) Refrigerant pipe wall thickness and material

- Select refrigerant pipes of the table shown on the right wall thickness and material as specified for each pipe size.

NOTE Select pipes having a wall thickness larger than the specified minimum pipe thickness.

Pipe diameter [mm]	ø6.35	ø9.52	ø12.7
Minimum pipe wall thickness [mm]	0.8	0.8	0.8
Pipe material*	O-type pipe	O-type pipe	O-type pipe

*Phosphorus deoxidized seamless copper pipe ICS 23.040.15, ICS 77.150.30

4) On-site piping work

IMPORTANT

Take care so that installed pipes may not touch components within a unit. If touching with an internal component, it will generate abnormal sounds and/or vibrations.

How to remove the side cover

Please remove the screw of a side cover and remove to the front.

- Carry out the on site piping work with the service valve fully closed.
- Give sufficient protection to a pipe end (compressed and blazed, or with an adhesive tape) so that water or foreign matters may not enter the piping.
- Bend a pipe to a radius as large as practical (R100~R150). Do not bend a pipe repeatedly to correct its form.
- Flare connection is used between the unit and refrigerant pipe. Flare a pipe after engaging a flare nut onto it. Flare dimensions for R410A are different from those for conventional R407C. Although we recommend the use of flaring tools designed specifically for R410A, conventional flaring tools can also be used by adjusting the measurement of protrusion B with a protrusion control gauge.
- The pipe should be anchored every 1.5m or less to isolate the vibration.
- Tighten a flare joint securely.

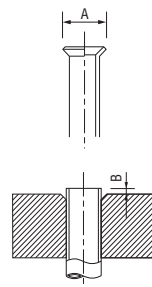
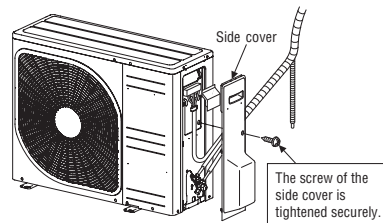

Flared pipe end : A (mm)

Copper pipe outer diameter	A
ø6.35	9.1
ø9.52	13.2
ø12.7	16.6

Copper pipe protrusion for flaring : B (mm)

Copper pipe outer diameter	In the case of a rigid (clutch) type	
	With an R410A tool	With a conventional tool
ø6.35	0~0.5	1.0~1.5
ø9.52		
ø12.7		

CAUTION

Do not apply force beyond proper fastening torque in tightening the flare nut.

Fix both liquid and gas service valves at the valve main bodies as illustrated on the right, and then fasten them, applying appropriate fastening torque.

Service valve size (mm)	Tightening torque (N·m)	Tightening angle (°)	Recommended length of a tool handle (mm)
ø6.35 (1/4")	14~18	45~60	150
ø9.52 (3/8")	34~42	30~45	200
ø12.7 (1/2")	49~61	30~45	250

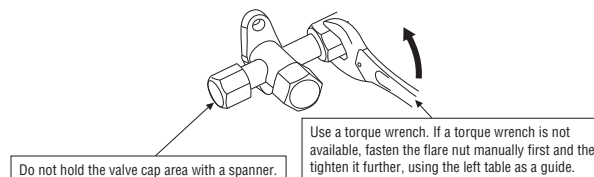

Do not hold the valve cap area with a spanner.

Use a torque wrench. If a torque wrench is not available, fasten the flare nut manually first and then tighten it further, using the left table as a guide.

5) Air tightness test

- ① Although outdoor and indoor units themselves have been tested for air tightness at the factory, check the connecting pipes after the installation work for air tightness from the service valve's check joint equipped on the outdoor unit side. While conducting a test, keep the service valve shut all the time.
 - a) Raise the pressure to 0.5MPa, and then stop. Leave it for five minutes to see if the pressure drops.
 - b) Then raise the pressure to 1.5MPa, and stop. Leave it for five more minutes to see if the pressure drops.
 - c) Then raise the pressure to the specified level (4.15MPa), and record the ambient temperature and the pressure.
 - d) If no pressure drop is observed with an installation pressurized to the specified level and left for about one day, it is acceptable. When the ambient temperature fall 1°C, the pressure also fall approximately 0.01MPa. The pressure, if changed, should be compensated for.
 - e) If a pressure drop is observed in checking e) and a) – d), a leak exists somewhere. Find a leak by applying bubble test liquid to welded parts and flare joints and repair it. After repair, conduct an air tightness test again.
- ② In conducting an air tightness test, use nitrogen gas and pressurize the system with nitrogen gas from the gas side. Do not use a medium other than nitrogen gas under any circumstances.

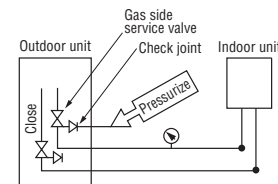

6) Evacuation

When the system has remaining moisture inside or a leaky point, the vacuum gauge indicator will rise. Check the system for a leaky point and then draw air to create a vacuum again.

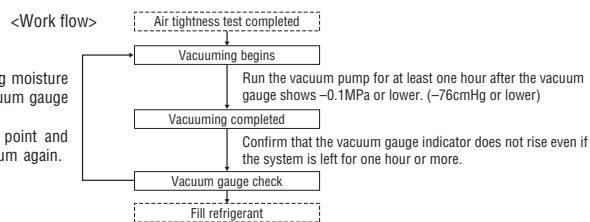

Pay attention to the following points in addition to the above for the R410A and compatible machines.

- To prevent a different oil from entering, assign dedicated tools, etc. to each refrigerant type. Under no circumstances must gauge manifold and a charge hose in particular be shared with other refrigerant types (R22, R407C, etc.).
- Use a counterflow prevention adapter to prevent vacuum pump oil from entering the refrigerant system.

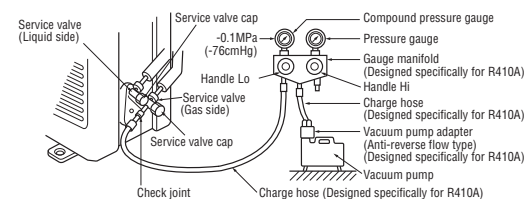

Securely tighten the service valve cap and the check joint blind nut after adjustment.

Service valve size (mm)	Service valve cap tightening torque (N·m)	Check joint blind nut tightening torque (N·m)
ø6.35 (1/4")	20 ~ 30	10 ~ 12
ø9.52 (3/8")		
ø12.7 (1/2")	25 ~ 35	

7) Additional refrigerant charge (Model SRC50/DXC18)

(1) Calculate a required refrigerant charge volume from the following table.

Model	Additional charge volume (kg) per meter of refrigerant piping (liquid pipe ø6.35)	Refrigerant volume charged for shipment at the factory (kg)	Installation's pipe length (m) covered without additional refrigerant charge
Model SRC50/DXC18	0.02	1.35	15

- This unit contains factory charged refrigerant covering 15m of refrigerant piping and additional refrigerant charge on the installation site is not required for an installation with up to 15m refrigerant piping. When refrigerant piping exceeds 15m, additionally charge an amount calculated from the pipe length and the above table for the portion in excess of 15m.

Formula to calculate the volume of additional refrigerant required

$$\text{Additional charge volume (kg)} = \{ \text{Main length (m)} - \text{Factory charged volume 15 (m)} \} \times 0.02 \text{ (kg/m)}$$

- * When an additional charge volume calculation result is negative, it is not necessary to charge refrigerant additionally.
- For an installation measuring 15m or shorter in pipe length, please charge the refrigerant volume charged for shipment at the factory, when you recharge refrigerant after servicing etc.

(2) Charging refrigerant

- Since R410A refrigerant must be charged in the liquid phase, you should charge it, keeping the container cylinder upside down or using a refrigerant cylinder equipped with a siphon tube.
- Charge refrigerant always from the liquid side service port with the service valve shut. When you find it difficult to charge a required amount, fully open the outdoor unit valves on both liquid and gas sides and charge refrigerant from the gas (suction) side service port, while running the unit in the cooling mode. In doing so, care must be taken so that refrigerant may be discharged from the cylinder in the liquid phase all the time. When the cylinder valve is throttled down or a dedicated conversion tool to change liquid phase refrigerant into mist is used to protect the compressor, however, adjust charge conditions so that refrigerant will gasify upon entering the unit.
- In charging refrigerant, always charge a calculated volume by using a scale to measure the charge volume.
- When refrigerant is charged with the unit being run, complete a charge operation within 30minutes. Running the unit with an insufficient quantity of refrigerant for a long time can cause a compressor failure.

NOTE Put down the refrigerant volume calculated from the pipe length onto the caution label attached on the service panel.

8) Heating and condensation prevention

- (1) Dress refrigerant pipes (both gas and liquid pipes) for heat insulation and prevention of dew condensation.
 - Improper heat insulation/anti-dew dressing can result in a water leak or dripping causing damage to household effects, etc.
- (2) Use a heat insulating material that can withstand 120°C or a higher temperature. Poor heat insulating capacity can cause heat insulation problems or cable deterioration.
 - All gas pipes must be securely heat insulated in order to prevent damage from dripping water that comes from the condensation formed on them during a cooling operation or personal injury from burns because their surface can reach quite a high temperature due to discharged gas flowing inside during a heating operation.
 - Wrap indoor units' flare joints with heat insulating parts (pipe cover) for heat insulation (both gas and liquid pipes).
 - Give heat insulation to both gas and liquid side pipes. Bundle a heat insulating material and a pipe tightly together so that no gaps may be left between them and wrap them together with a connecting cable by a dressing tape.
 - **Both gas and liquid pipes need to be dressed with 20mm or thicker heat insulation materials above the ceiling where relative humidity exceeds 70%.**

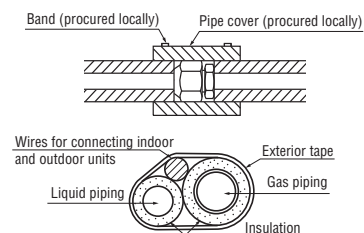

3. DRAIN PIPING WORK

- Execute drain piping by using a drain elbow and drain grommets supplied separately as accessories, where water drained from the outdoor unit is a problem.
- Water may drip where there is a larger amount of drain water. Seal around the drain elbow and drain grommets with putty or adequate caulking material.
- Condensed water may flow out from vicinity of operation valve or connected pipes.
- Where you are likely to have several days of sub-zero temperatures in a row, do not use a drain elbow and drain grommets. (There is a risk of drain water freezing inside and blocking the drain.)

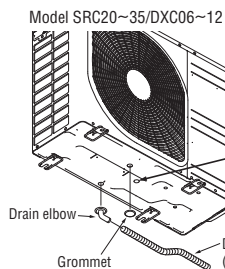

CAUTION
Do not put a grommet on this hole. This is a supplementary drain hole to discharge drain water, when a large quantity of it is gathered.

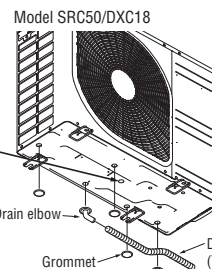

- When condensed water needs to be led to a drain, etc., install the unit on a flat base (supplied separately as an option part) or concrete blocks. Then, please secure space for the drain elbow and the drain hose.

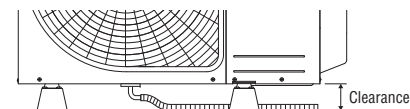

4. ELECTRICAL WIRING WORK For details of electrical cabling, refer to the indoor unit installation manual.

Electrical installation work must be performed by an electrical installation service provider qualified by a power provider of the country. Electrical installation work must be executed according to the technical standards and other regulations applicable to electrical installations in the country.

- Do not use any supply cord lighter than one specified in parentheses for each type below.
 - braided cord (code designation 60245 IEC 51)
 - ordinary tough rubber sheathed cord (code designation 60245 IEC 53)
 - flat twin tinsel cord (code designation 60227 IEC 41)
- Use polychloroprene sheathed flexible cord (code designation 60245 IEC57) for supply cords of parts of appliances for outdoor use.
- Ground the unit. Do not connect the grounding wire to a gas pipe, water pipe, lightning rod or telephone grounding wire. If improperly grounded, an electric shock or malfunction may result.
- A grounding wire must be connected before connecting the power cable. Provide a grounding wire longer than the power cable.
- The installation of an impulse withstanding type earth leakage breaker is necessary. A failure to install an earth leakage breaker can result in an accident such as an electric shock or a fire.
- Do not turn on the power until the electrical work is completed.
- Do not use a condensive capacitor for power factor improvement under any circumstances. (It does not improve power factor, while it can cause an abnormal overheat accident)
- For power source cables, use conduits.
- Do not lay electronic control cables (remote control and signaling wires) and other cables together outside the unit. Laying them together can result in the malfunctioning or a failure of the unit due to electric noises.
- Fasten cables so that they may not touch the piping, etc.
- When cables are connected, make sure that all electrical components within the electrical component box are free of loose connector coupling or terminal connection and then attach the cover securely. (Improper cover attachment can result in malfunctioning or a failure of the unit, if water penetrates into the box.)
- Never use a shield cable.
- SRC-ZMA-S, SRC-ZMXA-S and DXC-ZMA-S complies with the DRED (Demand Response Enabling Devices) standard AS/NZS4755.3.1 and supports demand response modes 1, 2, and 3 (DRM1, 2, and 3). Since the air-conditioner limits the electric power or energy by receiving the DRED input signal, the sense of cooling operation or heating operation may deteriorate over time. The outdoor unit of this air-conditioner is equipped with a terminal block for DRED input and supports ELV (Extra-Low Voltage) complying with AS/NZS60335.1.

CAUTION

In case of faulty wiring connection, the indoor unit stops, and then the run lamp turns on and the timer lamp blinks.

Use cables for interconnection wiring to avoid loosening of the wires. GENELEC code for cables Required field cables.

H05RNR4G1.5 (Example) or 245IEC57
 H Harmonized cable type
 05 300/500 volts
 R Natural-and/or synth. rubber wire insulation
 N Polychloroprene rubber conductors insulation
 R Stranded core
 4or5 Number of conductors
 G One conductor of the cable is the earth conductor (yellow/green)
 1.5 Section of copper wire (mm²)

Main fuse specification

Specification	Part No.
250V 15A	SSA564A136

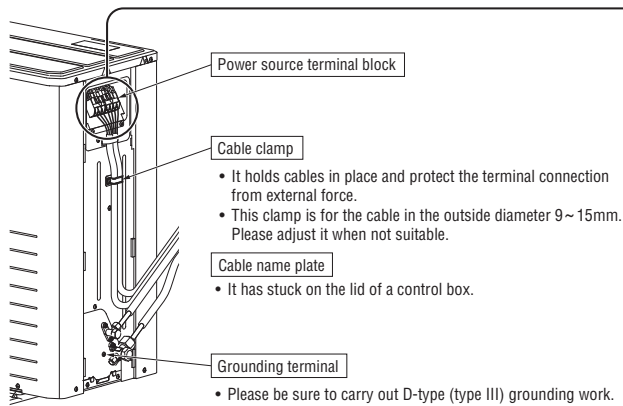

Power cable, indoor - outdoor connecting wire circuit diagram

Model SRC20~35ZM-S
Model SRC20~35ZMX-S
Model DXC06ZM-S

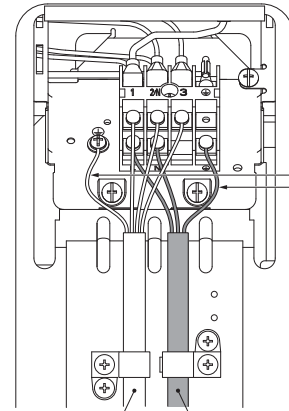

• Earth wire shall be Yellow/Green (Y/G) in color and longer than other AC wires for safety reason.

Model SRC20~35ZMA-S
Model SRC20~35ZMXA-S
Model DXC09,12ZMA-S

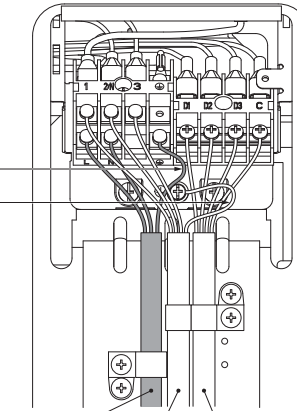

Power cable, indoor-outdoor connecting wires

Model SRC-ZM-S
Model SRC-ZMX-S
Model DXC-ZM-S

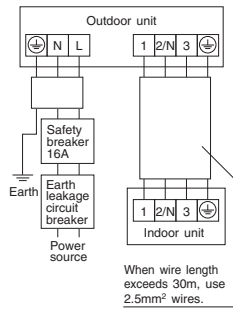

Model SRC-ZMA-S
Model SRC-ZMXA-S
Model DXC-ZMA-S

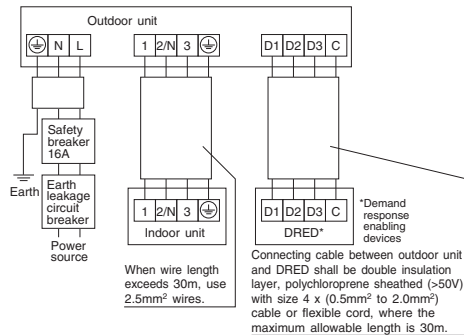

- Always perform grounding system installation work with the power cord unplugged.
- Connect a pair bearing a common terminal number with an indoor-outdoor connecting wire.
- In cabling, fasten cables securely with cable clamps so that no external force may work on terminal connections.
- Grounding terminals are provided in the control box.

CAUTION Always use an earth leakage circuit breaker designed for inverter circuits to prevent a faulty operation.

Phase	Earth leakage breaker	Switchgear or Circuit Breaker		Power source (minimum)	Interconnecting and grounding wires (minimum)
		Switch breaker	Over current protector rated capacity		
Single-phase	15A, 30mA, 0.1sec or less	30A	16A	2.0mm ²	1.5mm ² X 4

- The specifications shown in the above table are for units without heaters. For units with heaters, refer to the installation instructions of the indoor unit.
- Switchgear or Circuit breaker capacity which is calculated from MAX. over current should be chosen along the regulations in each country.
- The cable specifications are based on the assumption that a metal or plastic conduit is used with no more than three cables contained in a conduit and a voltage drop is 2%. For an installation falling outside of these conditions, please follow the internal cabling regulations. Adapt it to the regulation in effect in each country.

Model SRC50ZM-S

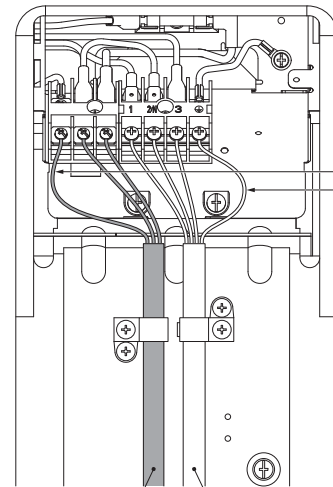

• Earth wire shall be Yellow/Green (Y/G) in color and longer than other AC wires for safety reason.

Model SRC50ZMA-S
Model DXC18ZMA-S

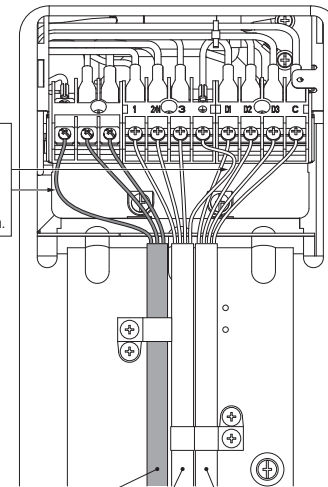

INSTALLATION TEST CHECK POINTS

Check the following points again after completion of the installation, and before turning on the power. Conduct a test run again and ensure that the unit operates properly. Explain to the customer how to use the unit and how to take care of the unit following the instruction manual.

After installation

- | | |
|--|---|
| <input type="checkbox"/> Power cables and connecting wires are securely fixed to the terminal block. | <input type="checkbox"/> The pipe joints for indoor and outdoor pipes have been insulated. |
| <input type="checkbox"/> The power source voltage is correct as the rating. | <input type="checkbox"/> The reverse flow check cap is attached. |
| <input type="checkbox"/> The drain hose is fixed securely. | <input type="checkbox"/> The cover of the pipe cover (A) faces downward to prevent rain from entering. |
| <input type="checkbox"/> Service valve is fully open. | <input type="checkbox"/> Gaps are properly sealed between the pipe covers (A) (B) and the wall surface / pipes. |
| <input type="checkbox"/> No gas leaks from the joints of the service valve. | <input type="checkbox"/> The screw of the side cover is tightened securely. |